



CLD

Pneumatic Torque Multiplier (Rotating Body Tool)

Model	Item #	Torque Ranges		Square Drive
		lbf.ft	N.m	
CLD55	210572	121 - 357	165 - 485	3/4"
CLD85	210573	225 - 660	305 - 895	3/4"
CLD85	210574	225 - 660	305 - 895	1"
CLD105	210575	270 - 796	365 - 1080	1"
CLD125	210576	332 - 970	450 - 1315	1"
CLD155	210577	435 - 1275	590 - 1730	1"
CLD225	210571	671 - 1970	910 - 2670	1"
CLD280	210578	870 - 2552	1180 - 3460	1"
CLD380	210579	1100 - 3230	1490 - 4380	1 1/2"
CLD580	210580	1534 - 4510	2080 - 6115	1 1/2"
CLD780	210581	1925 - 5660	2610 - 7675	1 1/2"
CLD980	210582	2810 - 8257	3810 - 11195	1 1/2"

Torque Multipliers

KEY FEATURES

- Accuracy better than $\pm 5\%$.
- Compact design is safe, easy, and simple to handle.
- Precision tightening and loosening of all heavy duty fastening connections.
- Flexible tool positioning with 360° rotating handle.
- Shuts-off when pre-set torque is achieved. Non-impacting and operates at a smooth, continuous rotation.
- Torque adjustment and control is regulated by the Lubro Control Unit (LCU) via the air supply.
- Multiplier increases speed and productivity, as it is faster than a hydraulic wrench and is less expensive. Eliminates the cumbersome set up time and slow ratcheting process of hydraulic wrenches.
- Ergonomically safer than the harmful hammering of impact wrenches. Eliminates the frequent costly repairs of impact wrenches.
- Heavy-duty gearbox.

Accessories



REACTION RING

Reaction Devices:
Foot, Bar and Ring.
See Page 01.13



6 PT. IMPACT SOCKETS

A wide range of durable sockets available.
See Page 01.14

Connect With A:

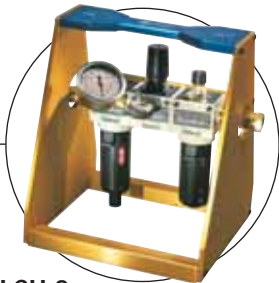

LCU-2

Our Lubro-Control Unit is designed to provide a controlled supply of filtered, regulated and lubricated compressed air to the Multiplier.
See Page 01.13

Model	Speed RPM	Spline Dia. mm	D2 mm	Length		Weight lbs.
				in.	mm	
CLD55	48	41	85	11	280	15
CLD85	25	41	85	11.8	300	18
CLD85	25	54	85	11.8	300	18
CLD105	15	54	85	11.8	300	18
CLD125	12	54	85	11.8	300	18
CLD155	10	54	85	11.8	300	18
CLD225	8	54	85	11.8	300	20
CLD280	6.5	54	85	11.8	300	20
CLD380	4	72	98	12.6	320	26
CLD580	2.5	72	123	13.8	350	35
CLD780	1	72	148	13.8	350	42
CLD980	0.5	91	173	14.6	370	55

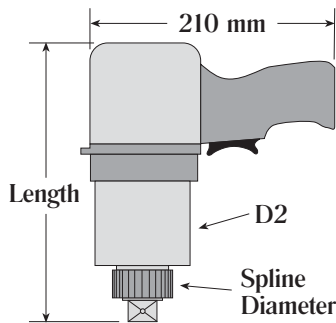

NOTE!

All Pneumatic Multipliers should use a high quality air filter regulator.

RENTAL!

Torque Multipliers are part of our Rental Program. Ask a customer service representative about availability.